

**Standard Construction and Materials**

- FRAME:** Frame optional. See Page 2 for available options.
- VBS:** 0.465" deep hat channel, 0.063" thick (nominal)  
6063-T5 aluminum alloy vertical blade support (VBS).
- BLADE:** 0.063" thick (nominal) extruded aluminum, 6063-T5 alloy.
- FINISH:** Mill

**Options**  
Finish - Anodized, Painted

**Notes**

1. 1/2" nominal deduction will be made to the opening size given.
2. Contact the factory for louver sizes larger than 96"W x 48"H.
3. Approximate shipping weight is 6.0 lbs./sq.ft.

**Louver Sizes**

Min Panel	Max Single Panel
12"W x 12"H	96"W x 48"H

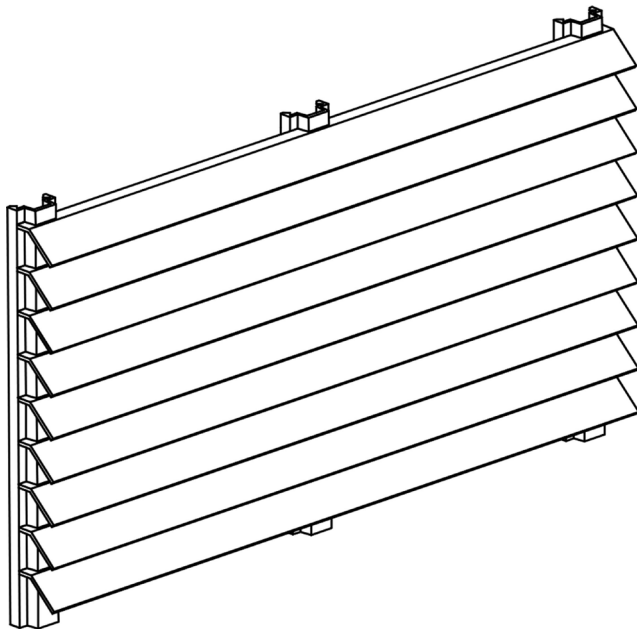
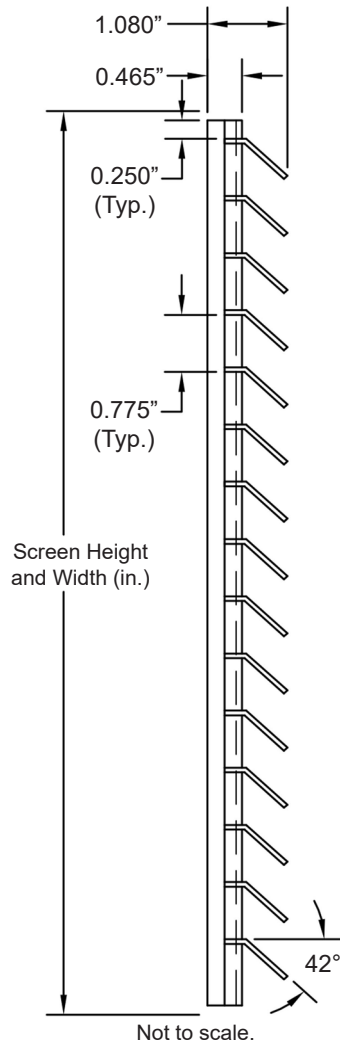

Not to scale.

										
<u>Item #</u>	<u>Qty</u>	<u>Width</u>	<u>Height</u>	<u>Width</u>	<u>Height</u>	<u>Mullion</u>				
		<u>Opening Size</u>		<u>Louver Size</u>						<u>Union Made</u>
<u>Arch. / Eng.:</u>				<u>EDR:</u>				<u>ECN:</u>		<u>Job:</u>
<u>Contractor:</u>										
<u>Project:</u>				<u>Date:</u>				<u>DWN:</u>		<u>DWG:</u>

In the interest of product development, Cesco Products reserves the right to make changes without notice.



450 Riverside Dr • Wyalusing PA, 18853  
 Phone: 570-746-1888 • Fax: 570-746-9286  
 www.cescoproducts.com

Free Area Tables

Free Area sq.ft. (sq.m.)

		Width in. (mm)							
		12" (305)	24" (610)	36" (914)	48" (1219)	60" (1254)	72" (1829)	84" (2134)	96" (2438)
Height in. (mm)	12" (305)	.52 (0.05)	1.11 (0.10)	1.69 (0.16)	2.32 (0.22)	2.90 (0.27)	3.48 (0.32)	4.06 (0.38)	4.69 (0.44)
	24" (610)	1.08 (0.10)	2.29 (0.21)	3.50 (0.33)	4.80 (0.45)	6.00 (0.56)	7.21 (0.67)	8.41 (0.78)	9.71 (0.90)
	36" (914)	1.63 (0.15)	3.44 (0.32)	5.25 (0.49)	7.20 (0.67)	9.01 (0.84)	10.81 (1.01)	12.62 (1.17)	14.58 (1.35)
	48" (1219)	2.19 (0.20)	4.62 (0.43)	7.05 (0.66)	9.68 (0.90)	12.11 (1.13)	14.54 (1.35)	16.97 (1.58)	19.60 (1.82)

Free Area (% Free Area)

		Width in. (mm)							
		12" (305)	24" (610)	36" (914)	48" (1219)	60" (1254)	72" (1829)	84" (2134)	96" (2438)
Height in. (mm)	12" (305)	52.00	55.50	56.33	58.00	58.00	58.00	58.00	58.63
	24" (610)	54.00	57.25	58.33	60.00	60.00	60.08	60.07	60.69
	36" (914)	54.33	57.33	58.33	60.00	60.07	60.06	60.10	60.75
	48" (1219)	54.75	57.75	58.75	60.50	60.55	60.58	60.61	61.25

Frame Options

